



The new 4-sensor flue gas analyzer for emission measurement in industry



More reliability, more convenience and even more parameters...



Rising fuel costs for thermal systems highlight more and more the need for efficiency monitoring using emission measurements. A practical, easy-to-use emission analyzer for a variety of applications is therefore ideal.

testo 340 is the hand-held analyzer for industrial flue gas analysis and offers benefits such as:

- 1** The unique measuring range extension feature facilitates unlimited measurements even at high gas concentrations.
- 2** testo 340 is equipped with an O₂ sensor as standard. 3 additional gas sensors can be individually configured at any time so your analyzer is optimally adapted to your measurement job.
- 3** Compact design combined with reliable engineering makes testo 340 the ideal analyzer for commissioning, service and maintenance work as well as measurements for monitoring purposes.
 - Industrial burners
 - Stationary industrial engines
 - Gas turbines
 - Thermal processes



TÜV approval / EN standard

- Accuracy approved for O₂, CO₂, CO, NO, NO_{low}, °C, hPa to EN 50379 standard, Part 2
- Approved sensor change (adjustment without test gas)

1

Automatic sensor protection at high gas concentrations: Measuring range extension

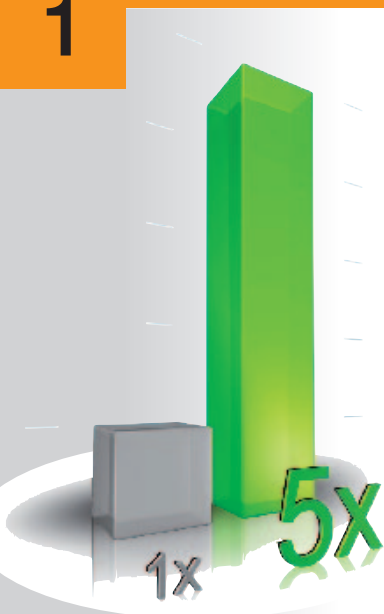

The benefits of this protection function:

- ✓ The measuring ranges of your CO, CO_{low}, NO, NO_{low} or SO₂ sensor is increased 5 times by automatic measuring range extension. At high gas concentrations the sensor is then not stressed any more than it would be at low concentrations.
- ✓ As an option, the measuring ranges of all the sensors in the analyzer can be extended simultaneously by a factor of 2.
- ✓ Measurements up to, for example max. 50,000 ppm (CO), or max. 15,000 ppm (NO), or max. 25,000 ppm (SO₂), without overloading the sensor.
- ✓ No additional sensors and costs with different measuring ranges.
- ✓ Automatic sensor protection from overloading, without interrupting the measurement.

testo 340 – Best support in flue gas analysis

Space for 4 gas sensors

testo 340 is fitted with an O₂ sensor as standard. Three additional toxic gas sensors such as CO, CO_{low}, NO, NO_{low}, NO₂ or SO₂ can be selected by the user. This guarantees highest flexibility when adapting to changing applications and measurement jobs.



The sensor can be changed or upgraded in an additional gas parameter by the user directly on-site...

The main advantage of this is that adjustment data is saved in the gas sensors. In this way, time-consuming test gas adjustment when changing sensors is dispensed with.



testo 340 means:

Simply select, change and add to, at any time, the gas sensors required. For this purpose, select from these 7 pre-calibrated gas sensors:

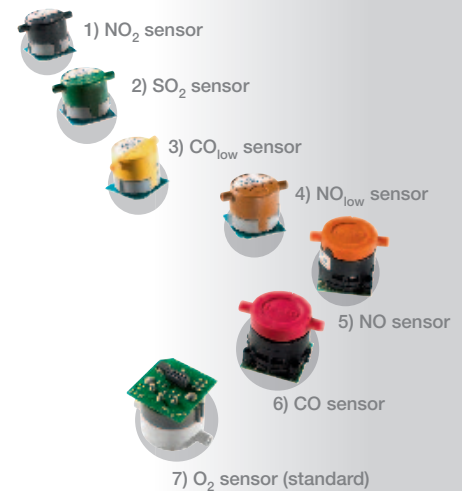

2

The right solution for every application...

More flexibility thanks to the powerful, automatically controlled diaphragm pump for measurements on different systems.

The automatically controlled measurement gas pump built into testo 340 is the ideal solution for typical situations which arise when measuring flue gas such as negative or positive pressure (from -200 to +50 mbar). Pump flow is automatically kept constant.

Increased safety thanks to a built-in condensate trap

The Testo design eliminates the possibility of condensation accumulating in the actual gas sensor. testo 340 warns if the condensate trap needs to be emptied.

A wide fuel selection is available
18 standard fuels and 10 additional user-defined fuels can be matched specifically to each application.

3

... the right flue gas sampling probe for every measurement task

Bigger selection...

Different probe shaft lengths, diameters and temperature ranges ensure high flexibility for all applications. To change, the probe shaft is simply attached to the probe handle and snaps into place.

Special flue gas probes for industrial engines are designed for positive pressure at the measurement site and also makes measurements in the toughest conditions possible. In

addition, modular industrial probes are available for rugged process conditions.

Ready-to-operate immediately

The highly robust fast-action probe coupling for all gas paths eliminates any mix-ups. The indestructible gas sampling hose cannot be bent, can be extended up to 7.8 m and saves space. The probe can remain positioned in the flue gas during the

zeroing phase of the gas sensors.

The calibration phase of testo 340 is finished after only 30 seconds.



testo 340 – The ideal tool for service, maintenance and inspections

Your low-budget entry into industrial emission measurement



Ideal order suggestion for this application

	Part no.
testo 340 flue gas analyzer incl. rechargeable battery, calibration protocol and carry strap, equipped with O ₂ sensor and built-in flow/differential pressure measurement	0632 3340
Option: CO (H ₂ compensated) measurement module, 0 to 10,000 ppm	0393 1100
Flue gas probe, modular, 335 mm immersion depth, incl. probe stop, thermocouple NiCr-Ni (Ti) Tmax 500°C and hose 2.2 m	0600 9766
100-240 V AC / 6.3 V DC international mains unit	0554 1096
Option: BLUETOOTH® module	0440 0784
BLUETOOTH® printer set with wireless Bluetooth interface, incl. 1 roll thermal paper, rechargeable battery and mains unit	0554 0553
Transport case for analyzer and probes	0516 3400

testo 340's high measurement accuracy and easy handling enable efficient and reliable "emission checks" for fast assessment of industrial combustion systems:

- ✓ **Spot measurements for up to two hours**
testo 340 can independently run 5 user-defined measurement programs. Spot measurements of up to max. two hours are therefore possible. Measurement is also possible "online" using Bluetooth or a USB cable.
- ✓ **Simultaneous differential pressure measurement**
Simultaneous measurement of flue gas and flow velocity allows calculation of current mass flow.
- ✓ **At different measurement points in your system**
Battery operation possible thanks to battery life of more than six hours.
- ✓ **Highest flexibility in the selection of sensors**
Equipped with an O₂ sensor as standard, 3 additional gas parameters can be freely selected from the following 6: CO, CO_{low}, NO, NO_{low}, NO₂ and SO₂.

For service and maintenance work on industrial burners and furnaces

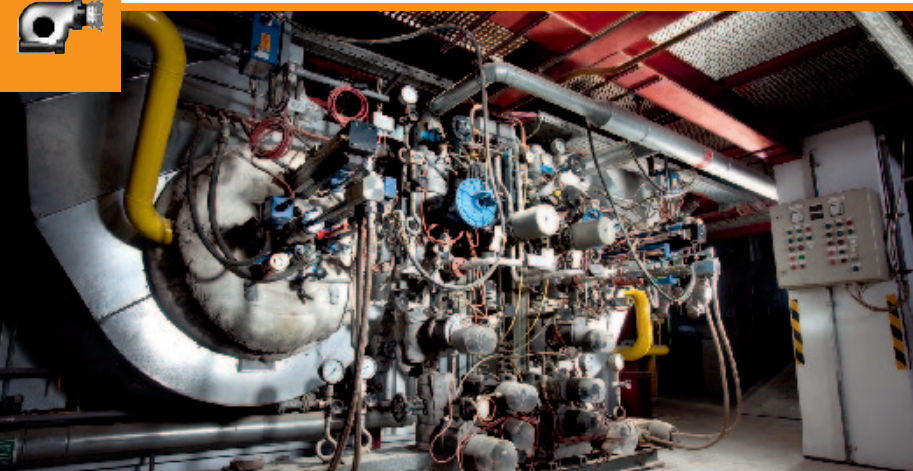

Ideal order suggestion for this application

	Part no.
testo 340 flue gas analyzer incl. rechargeable battery, calibration protocol and carry strap, equipped with O ₂ sensor and built-in flow/differential pressure measurement	0632 3340
Option: CO (H ₂ compensated) measurement module, 0 to 10,000 ppm	0393 1100
Option: NO measurement module, 0 to 3,000 ppm*	0393 1150
Option: SO ₂ measurement module, 0 to 5,000 ppm	0393 1250
Flue gas probe, modular, 335 mm immersion depth, incl. probe stop, thermocouple NiCr-Ni (Ti) Tmax 1000°C and hose 2.2 m	0600 8764
"easyEmission" software with USB cable to connect instrument to PC	0554 3334
Transport case for analyzer and probes	0516 3400

*We recommend the NO_{low} sensor (0393 1152) to measure low NO values.

testo 340 offers many technical functions for safe and efficient commissioning, tuning, efficiency optimization and troubleshooting when servicing industrial burners:

- ✓ **Direct display of air ratio and efficiency**
All relevant combustion and calculation parameters for optimum tuning are clearly shown in the display.
- ✓ **Measuring range extension and automatic sensor protection**
When commissioning burners or carrying out measurements on unfamiliar systems, very high concentrations can occur unexpectedly. In cases like these, the measuring range extension is automatically activated. This protects the sensor, as the load placed on it is no higher than at low concentrations.
- ✓ **Always ready for use – even in rough daily work**
The robust housing protects the analyzer from impact.

Supports inspections and tuning work on stationary industrial engines...

Versatile combination options of the different gas sensors in testo 340 offer you the highest level of flexibility in measurements on stationary engines:

✓ Separate NO and NO₂ measurement

The real NO_x value is measured with the sensor combination of NO and NO₂. In gas engines, the NO₂ component of the NO_x value can fluctuate greatly, so separate measurement of both gases is necessary for correct NO_x values.

✓ Measurements even at high CO concentrations

Even at unexpectedly high concentrations (up to 50,000 ppm), automatic dilution of the sensor with fresh air allows measurements even when the engine status is undefined, without negatively influencing the life expectancy of the sensor.

✓ Special flue gas probes for industrial engines as accessories

These probes are highly heat-resistant and are specially designed to compensate different pressure conditions, for example in measurements before and after the catalytic converter.

✓ Engine-specific parameters

The most important parameters for industrial engines such as O₂, CO, NO, NO₂, NO_x and Lambda can be displayed simultaneously.

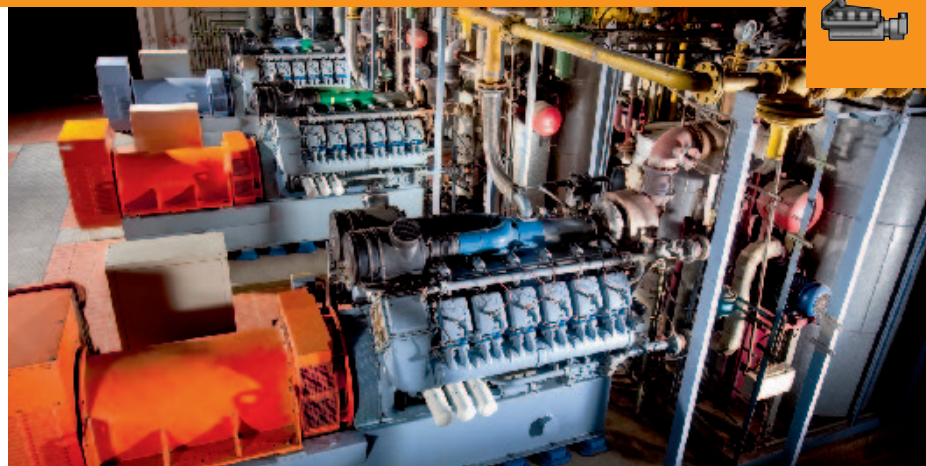

Ideal order suggestion for this application

	Part no.
testo 340 flue gas analyzer incl. rechargeable battery, calibration protocol and carry strap, equipped with O ₂ sensor and built-in flow/differential pressure measurement	0632 3340
Option: CO (H ₂ compensated) measurement module, 0 to 10,000 ppm	0393 1100
Option: NO measurement module, 0 to 3,000 ppm	0393 1150
Option: NO ₂ measurement module, 0 to 500 ppm	0393 1200
Flue gas probe for industrial motors, 335 mm immersion depth, with probe stop, built-in condensate trap and heat protection plate, Tmax 1000 °C, special hose for NO ₂ /SO ₂ measurements, 2.2 m long*	0600 7560
Option: dilution of all sensors	0440 3350
100-240 V AC / 6.3 V DC international mains unit	0554 1096
"easyEmission" software with USB cable to connect instrument to PC	0554 3334
Transport case for analyzer and probes	0516 3400

*We recommend the flue gas probe with probe pre-filter (0600 7561) for measurements on stationary diesel engines.

...and for measurements on turbines

To reduce emissions from gas turbines, CO and NO measurements using testo 340 in low ranges are necessary. The CO_{low} and NO_{low} sensors in testo 340 are ideally suited to this task:

✓ Special NO_{low} sensor for low concentrations

The NO_{low} sensor for measurements on LowNO_x turbines can be freely combined with other sensors.

✓ Measuring range extension and CO_{low} sensor

Thanks to the measuring range extension, the CO_{low} sensor can measure up to 2,500 ppm without any problems.

✓ Easy and accurate test gas adjustment by the user

If required, testo 340 can be easily adjusted with test gas on site.

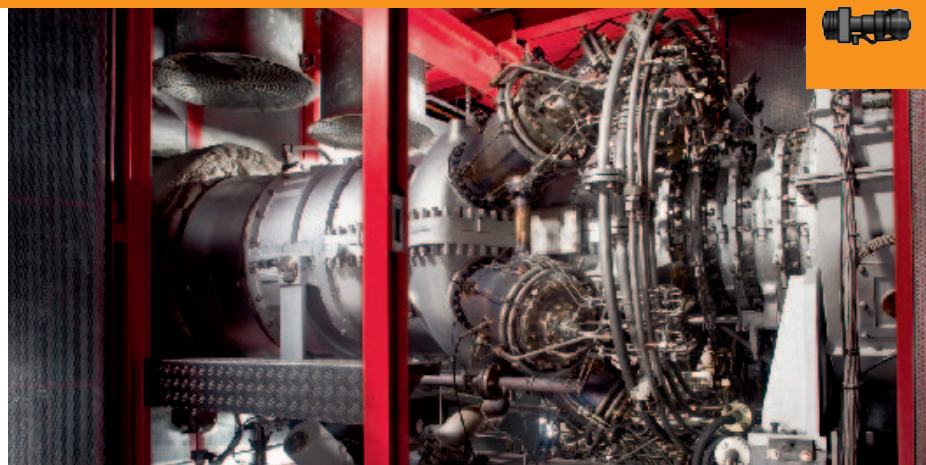

Ideal order suggestion for this application

	Part no.
testo 340 flue gas analyzer incl. rechargeable battery, calibration protocol and carry strap, equipped with O ₂ sensor and built-in flow/differential pressure measurement	0632 3340
Option: CO (H ₂ compensated) measurement module, 0 to 10,000 ppm*	0393 1100
Option: NO _{low} measurement module, 0 to 300 ppm	0393 1152
Option: NO ₂ measurement module, 0 to 500 ppm	0393 1200
Flue gas probe for industrial motors, 335 mm immersion depth, with probe stop, built-in condensate trap and heat protection plate, Tmax 1000 °C, special hose for NO ₂ /SO ₂ measurements, 2.2 m long	0600 7560
100-240 V AC / 6.3 V DC international mains unit	0554 1096
"easyEmission" software with USB cable to connect instrument to PC	0554 3334
Transport case for analyzer and probes	0516 3400

*We recommend the CO_{low} sensor (0393 1102) for measuring low CO values.

Data communication – That's how easy it is

Wireless reading out, transmission and printing of readings



Bluetooth
Wireless transmission*

*Country permits/BLUETOOTH® wireless transmission, see Technical Data on page 7.

The new communication interface: **Bluetooth® 2.0**

Wireless connection via **Bluetooth® 2.0** to testo **BLUETOOTH®** printers and direct communication to Notebook/PC over a distance of up to 10m (free field) are features of the new testo 340 option. Readings and configurations are transmitted wirelessly to your Notebook/PC for storage and analysis.

testo printers

Print data is transmitted wirelessly to the printer by infrared interface (visual contact required) or by new **BLUETOOTH®** wireless transmission. This saves time since the analyzer is ready for use again immediately following data transmission.



Convenient measurement data management with "easyEmission"



Data can be read out, easily edited, filed and managed using "easyEmission" software:

Benefits of easyEmission:

- ✓ Readings are shown in table or graph form
- ✓ User-defined measurement spacing (from one measurement / second to one measurement / hour)
- ✓ Online measurements via **BLUETOOTH®** wireless transmission or USB connection
- ✓ Customer and application-specific measurement logs
- ✓ Data structure and measurement information can be transmitted from computer to analyzer
- ✓ All instrument configurations and settings can be easily carried out with easyEmission
- ✓ Direct transmission to Excel and pdf formats
- ✓ Easy implementation of individual formulae for your own calculations
- ✓ Calculation of fuel factors when using customer-specific fuels

Technical data

	Meas. range	Accuracy	Resolution	Response time
O₂ measurement	0 to 25 Vol. %	±0.2 Vol. %	0.01 Vol. %	t ₉₀ < 20 s
CO measurement (H₂ compensated)	0 to 10.000 ppm	±10 ppm or ±10% of mv (0 to 200 ppm) ±20 ppm or ±5% of mv (201 to 2.000 ppm) ±10% of mv (2.001 to 10.000 ppm)	1 ppm	t ₉₀ < 40 s
CO_{low} measurement (H₂ compensated)	0 to 500 ppm	±2 ppm (0 to 39.9 ppm) ±5% of mv (remaining range) ^x ^x data corresponds to 20°C ambient temperature. Additional temperature coefficient 0.25% of reading/K.	0.1 ppm	t ₉₀ < 40 s
NO measurement	0 to 3.000 ppm	±5 ppm (0 to 99 ppm) ±5% of mv (100 to 1.999 ppm) ±10% of mv (2.000 to 3.000 ppm)	1 ppm	t ₉₀ < 30 s
NO_{low} measurement	0 to 300 ppm	±2 ppm (0 to 39.9 ppm) ±5% of mv (remaining range)	0.1 ppm	t ₉₀ < 30 s
NO₂ measurement*	0 to 500 ppm	±10 ppm (0 to 199 ppm) ±5% of mv (remaining range)	0.1 ppm	t ₉₀ < 40 s
SO₂ measurement*	0 to 5.000 ppm	±10 ppm (0 to 99 ppm) ±10% of mv (remaining range)	1 ppm	t ₉₀ < 40 s
Temperature meas. Probe type Type K (NiCr-Ni)	-40 to +1.200 °C	±0.5 °C (0 to +99 °C) ±0.5 % of mv (remaining range)	0.1 °C	
Draught measurement	-40 to +40 hPa	±0.03 hPa (-2.99 to +2.99 hPa) ±1.5 % of mv (remaining range)	0.01 hPa	
Differential pressure measurement	-200 to 200 hPa	±0.5 hPa (-49.9 to 49.9 hPa) ±1.5 % of mv (remaining range)	0.1 hPa	
Absolute pressure measurement	600 to +1.150 hPa	±10 hPa	1 hPa	
Derived parameters				
Efficiency	0 to 120 %		0.1 %	
Flue gas loss	0 to 99.9 %		0.1 %	
Flue gas dewpoint	0 to 99.9 °C		0.1 °C	
CO₂ measurement (calculation from O₂)	0 to CO ₂ max.	±0.2 Vol. %	0.1 Vol. %	Response time t ₉₀ = < 40 s

*To avoid absorption, a maximum measurement duration of 2 hours should not be exceeded.

Country permits BLUETOOTH® wireless transmission for testo 340

The BLUETOOTH® radio module used by Testo is permitted for the following countries and may only be used in those countries, i.e. the BLUETOOTH® wireless transmission may not be used in any other country!

Europe including all EU member states

Austria, Belgium, Bulgaria, Cyprus, Czech Republic, Denmark, Estonia, Finland, France, Germany, Great Britain, Greece, Hungary, Ireland, Italy, Latvia, Lithuania, Luxembourg, Malta, Netherlands, Poland, Portugal, Romania, Slovakia, Slovenia, Spain, Sweden and Turkey

European countries (EFTA)

Iceland, Liechtenstein, Norway, Switzerland

Non-European countries

Canada, USA, Japan, Ukraine, Australia, Colombia and El Salvador

Measuring range extension		
Single dilution, factor 5 (standard)		
CO measurement (H₂ compensated)	Meas. range Accuracy Resolution	700 ppm to 50.000 ppm ±10 % of mv (additional error) 1 ppm
CO_{low} measurement (H₂ compensated)	Meas. range Accuracy Resolution	300 ppm to 2.500 ppm ±10 % of mv (additional error) 0.1 ppm
NO measurement	Meas. range Accuracy Resolution	500 ppm to 15.000 ppm ±10 % of mv (additional error) 1 ppm
NO_{low} measurement	Meas. range Accuracy Resolution	150 ppm to 1.500 ppm ±10 % of mv (additional error) 0,1 ppm
SO₂ measurement	Meas. range Accuracy Resolution	500 ppm to 25.000 ppm ±10 % of mv (additional error) 1 ppm
Dilution of all sensors, factor 2 (option, Part no. 0440 3350)		
O₂ measurement	With measuring range extension switched on over all sensors: Meas. range: Accuracy: Resolution:	0 to 25 vol.% ±1 vol.% additional error (0 to 4.99 vol.%) ±0.5 vol.% additional error (5 to 25 vol.%) 0.01 vol.%
CO measurement (H₂ compensated)	Meas. range Accuracy Resolution	700 ppm to 20.000 ppm ±10 % of mv (additional error) 1 ppm
CO_{low} measurement (H₂ compensated)	Meas. range Accuracy Resolution	300 ppm to 1.000 ppm ±10 % of mv (additional error) 0.1 ppm
NO measurement	Meas. range Accuracy Resolution	500 ppm to 6.000 ppm ±10 % of mv (additional error) 1 ppm
NO_{low} measurement	Meas. range Accuracy Resolution	150 ppm to 600 ppm ±10 % of mv (additional error) 0.1 ppm
NO₂ measurement	Meas. range Accuracy Resolution	200 ppm to 1.000 ppm ±10 % of mv (additional error) 0.1 ppm
SO₂ measurement	Meas. range Accuracy Resolution	500 ppm to 10.000 ppm ±10 % of mv (additional error) 1 ppm
General technical data		
Memory	Maximum Per folder Per site The max. number of logs is determined by the number of folders or sites	100 folders Max. 10 sites Max. 200 logs
Regulated diaphragm pump	Pump flow Hose length Max. pos. pressure/ flue gas Max. neg. pressure/ flue gas	0.6 l/min (regulated) max. 7.8 m (corresponds to two probe hose extensions) +50 mbar -200 mbar
User-defined fuels		10 user-defined fuels incl. test gas as fuel
Weight		960 g
Dimensions		283 x 103 x 65 mm
Storage temp.		-20 to +50 °C
Oper. temp.		-5 to +50 °C
Display		Graphic display 160 x 240 pixels
Power supply		Battery block 3.7 V / 2.4 Ah Mains unit 6.3 V / 2 A
Material/Housing		TPE PC
Protection class		IP40
Warranty	Analyzer: Rech. batt.: Sensors: CO, NO, CO _{low} , NO _{low} , NO ₂ , SO ₂ : O ₂ :	2 years (excluding working parts, e.g. sensors, sensor replacement filter) 1 year 1 year 1 year 1.5 years

Ordering data

Analyzer / Options	Part no.
testo 340 flue gas analyzer incl. rechargeable battery, calibration protocol and carry strap, equipped with O ₂ sensor and built-in flow/differential pressure measurement	0632 3340
testo 340 must be equipped with a second gas sensor otherwise the analyzer cannot function. Max. 3 additional sensors can be fitted.	
Option: CO (H ₂ compensated) measurement module, 0 to 10,000 ppm	0393 1100
Option CO _{low} (H ₂ compensated) measurement module, 0 to 500 ppm	0393 1102
Option: NO measurement module, 0 to 3,000 ppm	0393 1150
Option: NO _{low} measurement module, 0 to 300 ppm	0393 1152
Option: NO ₂ measurement module, 0 to 500 ppm	0393 1200
Option: SO ₂ measurement module, 0 to 5,000 ppm	0393 1250
Option: BLUETOOTH® module	0440 0784
Option: dilution of all sensors	0440 3350

Accessories	Part no.
Transport case for analyzer and probes	0516 3400
100-240 V AC / 6.3 V DC international mains unit, for mains operation or battery charging in instrument	0554 1096
"easyEmission" software with USB cable to connect instrument to PC	0554 3334
Multiple license/"easyEmission" software	0554 3338
Testo fast printer with wireless infrared interface, 1 roll thermal paper and 4 AA batteries	0554 0549
BLUETOOTH® printer set with wireless Bluetooth interface, incl. 1 roll thermal paper, rechargeable battery and mains unit	0554 0553
Spare thermal paper for printer (6 rolls), permanent ink	0554 0568
Spare thermal paper for printer (6 rolls)	0554 0569
Charger for spare battery	0554 1103
Instrument cleaner (100 ml)	0554 1207
NO replacement filter, 1 off	0554 4150
CO replacement filter, 1 off	0554 4100
ISO calibration certificate/flue gas, calibration points 2.5% O ₂ ; 100 and 1000 ppm CO; 800 ppm NO; 80 ppm NO ₂ ; 1000 ppm SO ₂	0520 0003

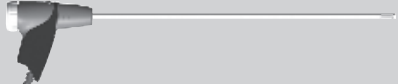
Standard gas sampling probes	Part no.
Modular flue gas probes, available in 2 lengths, incl. probe stop, NiCr-Ni thermocouple, 2.2 m hose and particle filter	
Flue gas probe, modular, 335 mm immersion depth, incl. probe stop, thermocouple NiCr-Ni (Ti) Tmax 500°C and hose 2.2 m	0600 9766
Flue gas probe, modular, 700 mm immersion depth, incl. probe stop, thermocouple NiCr-Ni (Ti) Tmax 500°C and hose 2.2 m	0600 9767
Flue gas probe, modular, 335 mm immersion depth, incl. probe stop, thermocouple NiCr-Ni (Ti) Tmax 1000°C and hose 2.2 m	0600 8764
Flue gas probe, modular, 700 mm immersion depth, incl. probe stop, thermocouple NiCr-Ni Tmax 1000°C and hose 2.2 m	0600 8765
Flue gas probe, modular, with preliminary filter, 335 mm immersion depth, incl. probe stop, thermocouple NiCr-Ni (Ti) Tmax 1000°C and hose 2.2 m	0600 8766
Flue gas probe, modular, with preliminary filter, 700 mm immersion depth, incl. probe stop, thermocouple NiCr-Ni (Ti) Tmax 1000°C and hose 2.2 m	0600 8767

Probe accessories/Standard gas sampling probes	Part no.
Hose extension, 2.8 m, extension cable for probe and analyser	0554 1202
Probe shaft with preliminary filter, 335 mm long, with probe stop, Ø 8 mm, Tmax 1000 °C	0554 8766
Probe shaft with preliminary filter, 700 mm long, with probe stop, Ø 8 mm, Tmax 1000 °C	0554 8767
Spare sintered filter (2 off)	0554 3372
Spare particle filter (10 off) for probe handle	0554 3385
Probe shaft, 700 mm long, with probe stop, Ø 8 mm, Tmax 500 °C	0554 9767
Probe shaft, 335 mm long, with probe stop, Ø 8 mm, Tmax 1000 °C	0554 8764
Probe shaft, 700 mm long, with probe stop, Ø 8 mm, Tmax 1000 °C	0554 8765

Probes	Part no.
Motor probes	
Flue gas probe for industrial motors, 335 mm immersion depth, with probe stop, built-in condensate trap and heat protection plate, Tmax 1000 °C, special hose for NO ₂ /SO ₂ measurements, 2.2 m long	0600 7560
Flue gas probe for industrial motors with probe shaft prefilter, 335 mm immersion depth, with probe stop, built-in condensate trap and heat protection plate, Tmax 1000 °C, special hose for NO ₂ /SO ₂ measurements, 2.2 m long	0600 7561
Thermocouple for exhaust gas temperature measurement (NiCr-Ni, length 400 mm, Tmax. +1000 °C), with 2.4 m connection cable and additional temperature protection	0600 8894
Spare particle filter (10 off) for condensate trap in gas sampling hose	0554 3371
Spare sintered filter (2 off)	0554 3372

Industry probes	Part no.
Adapter, non-heated	0600 7911
Extension pipe to +600 °C, stainless steel 1.4571	0600 7802
Extension pipe to +1200 °C, Inconel 625	0600 7804
Non-heated sampling pipe to +600 °C, stainless steel 1.4571	0600 7801
Non-heated sampling pipe to +1200 °C, Inconel 625	0600 7803
Non-heated sampling pipe to +1800 °C, Al-Oxide	0600 7805
Preliminary filter for dusty flue gases, ceramic Preliminary filter can only be mounted on extension pipe 0600 7802 or 0600 7804.	0554 0710
Gas sampling hose for accurate NO ₂ /SO ₂ measurements with built-in condensate trap, 2.2 m long	0554 3352
Thermocouple, NiCr-Ni, -200 to +1200 °C, Inconel 625, 1.2 m long	0430 0065
Thermocouple, NiCr-Ni, -200 to +1200 °C, Inconel 625, 2.2 m long	0430 0066
Thermocouple, NiCr-Ni, -200 to +1200 °C, Inconel 625, 3.2 m long	0430 0067
Mounting flange, stainless steel 1.4571, adjustable quick-action fitting suitable for all sampling/extension pipes	0554 0760
Spare particle filter (10 off) for condensate trap in gas sampling hose	0554 3371

Temperature probes	Part no.
Mini ambient air probe, Tmax +80°C, for separate ambient air temperature measurement	0600 3692
Pipe wrap probe for pipes with diameter of up to 2", for flow/return temp. meas. in hydronic systems	0600 4593
Mini ambient air probe, 60 mm immersion depth, w. probe stop, magnetic clip, Tmax +100°C, for dual wall clearance temp. meas. in systems w. outside primary air intakes	0600 9797
Pitot tubes	
Pitot tube, 350 mm long, stainless steel, measures velocity speed	0635 2145
Pitot tube, 1000 mm long, stainless steel, measures velocity speed	0635 2345
Pitot tube, stainless steel, 350 mm long, measures flow speed with temperature, 3 x hoses (5 m long) and heat protection plate	0635 2041
Pitot tube, stainless steel, 750 mm long, measures flow speed with temperature, 3x hoses (5 m long) and heat protection plate	0635 2042

Additional probe accessories	Part no.
Connection hose, silicone, 5m long, max. load 700 hPa (mbar)	0554 0440

Calibration Certificates	Part no.
ISO calibration certificate velocity, hot wire, vane anemometer, Pitot tube; calibration points 1; 2; 5; 10 m/s	0520 0004
ISO calibration certificate/Velocity, hot wire, vane anemometer, Pitot tube; calibration points 5; 10; 15; 20 m/s	0520 0034

TennMax Electronics S/B,
Unit 2-1-1, Ground Floor, Suria Avenue,
Jalan Dawai 16/2, Seksyen 16,
40200 Shah Alam, Selangor,
Malaysia.

Tel : 03-55131288/55194288

Fax : 03-55196288 Email : sales@testomalaysia.com.my